

TECHNICAL INSTRUCTIONS

RUMBA



DV9002
DECEMBER 2008 EDITION

UNIC

1. PREPARATION OF THE SITE

The machine is delivered in a cardboard box screwed onto a wooden pallet.

A. Unpack the machine

- Cut the tightening strap with shears.
- Open the cardboard box and take the accessories' container out.
- Make screws loose by slightly inclining the cardboard box.
- Take the machine out of the cardboard box and put it on wooden blocks.
- Remove screws and washers used for transport.

B. Install the machine and preparation of the site

- Put the machine in its final place and level it up with the help of rubber washers, as necessary.
- The machine must be placed on a horizontal surface.
- There must be a free space of 5 cm behind the machine and the ventilation holes on the top of the machine must not be obstructed.
- A socket with a ground system and a water-supply pipe corresponding to the characteristics of the machine are sufficient for connecting.

Set up cup racks after making adjustments.

2. HYDRAULIC CONNECTION

A water softener is necessary.

Water Intake

- Pressure ranging from 0 to 10 bar
- Connection : 3/8 gas female socket (male plug on machine)
- Pipe with a minimum 8 mm internal diameter
- Stop valve to be set up.

Drainage

- Connection : 3/4 gas female socket (male plug on machine)
- Pipe with a minimum 12 mm internal diameter.

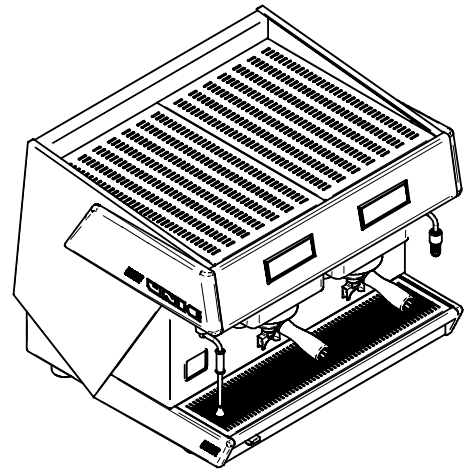

3. ELECTRIC CONNECTION

- None of the switches must be in ON position.
- Make sure that the voltage, frequency and power values marked on the descriptive plate of the machine are in conformity with the electric network mains.
- Mount a plug on the end of the machine cable (plug with grounding: green/yellow wire).

POWER CONNECTIONS

Set the machine switch to Position .

The machine is delivered with a cable consisting of 5 numbered wires.

Make sure that the machine connection matches the available voltage network (see wiring diagrams hereunder). Bring the necessary modifications into the supply cable and the plug located near the electrically-driven pressostat.

WIRING DIAGRAMS

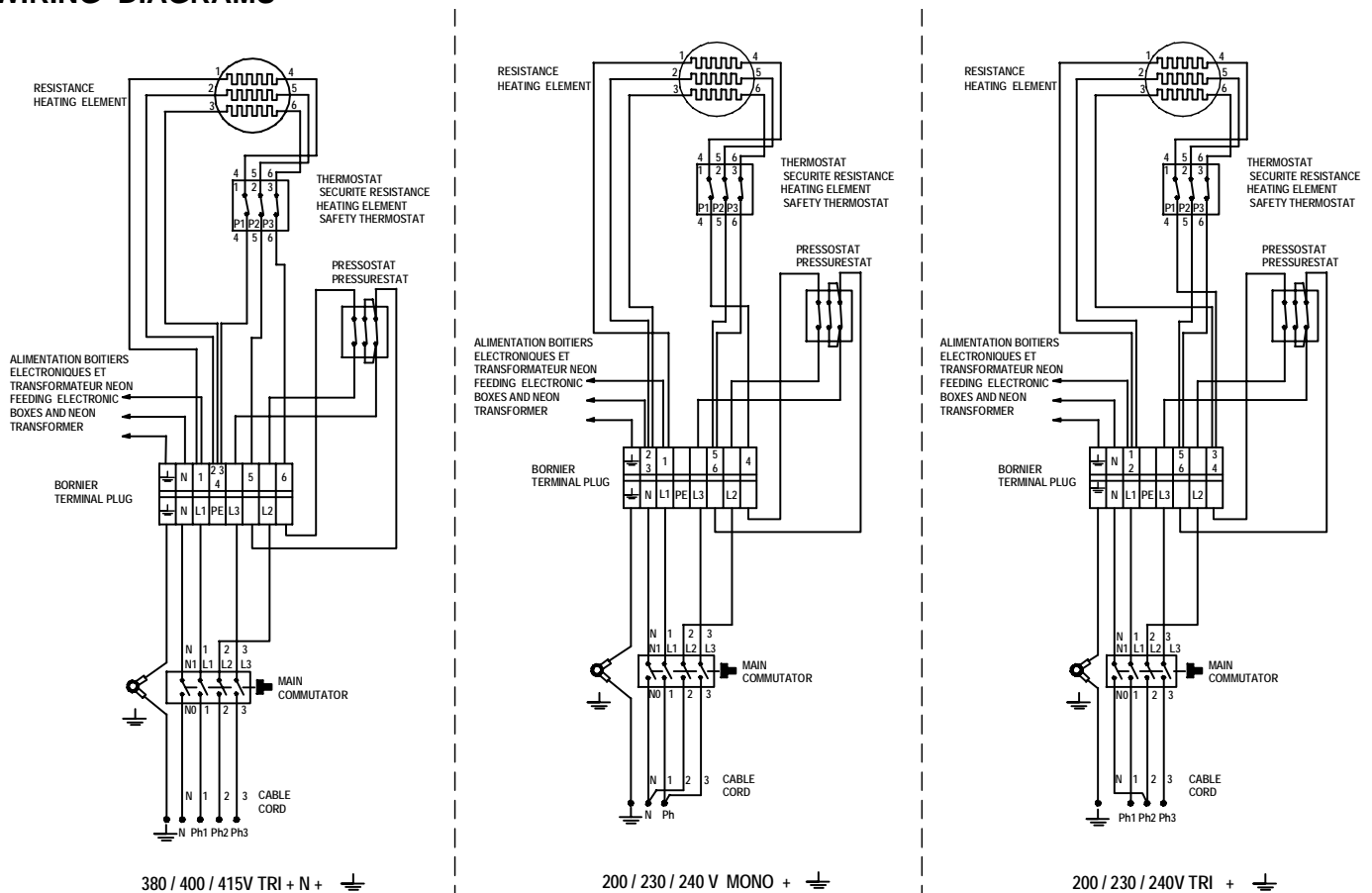

N = NEUTRE / NEUTRAL
 1 = PHASE MARRON / BROWN
 2 = PHASE NOIR / BLACK
 3 = PHASE GRIS / GREY

A : Electronic box
 B : Switch

IN ALL CASES, THE GREEN/YELLOW WIRE MUST BE EARTHED

4. STARTING-UP

4.1 FILLING THE BOILERS

- Turn on the shutoff valve.
- Plug in the machine.
- Set the charge switch to Position **1**. Do not set the charge switch to Position **2** until the boiler has been filled.

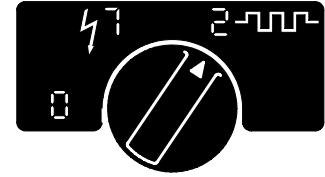

ON/OFF SWITCH

4.1a STEAM BOILER

- As soon as the machine is turned on, the filling takes place automatically. A safety is programmed, if the filling does not occur before 3 minutes. In this special case, the electrovalve and the pump are cut off. The indicator light blinks when steam and hot water outlets are not activated. If after 3 minutes the indicator light is still blinking :

- Check the hydraulic connection of the machine.
- Switch off and switch on the machine by setting the charge switch to Position **0** then to position **1**.

The filling starts again and lasts 3 minutes.

4.1b INTERNAL BOILERS

- With the filter holder in place, press the continuous/stop key of each unit.



As soon as the water flows correctly from the spout (with no air), press the same key again to stop the water.

4.2 HEATING

- When the boilers have been filled, Set the charge switch to Position **2**.
- When the operating temperature of the machine is reached, the pressure-gauge must indicate a pressure of 0.9 to 1 bar (red scale).

It is better to keep the machine switched on permanently and the filter-holders inserted in machine even when you are not making coffees.

5. CHECKS AND ADJUSTMENTS

.To get to the various adjustments, the cup rack, the rear panel or the sides must be removed.

Proceed as follows:

.CUP RACK:

Remove the grids, than unscrew the 4 upper screws and the two side screws. Than remove the cup rack.

.REAR PANEL(S):

Unscrew the 2 screws located inside the machine at its back; than make the panel(s) glide laterally.

.SIDES:

On each side, unscrew 2 screws of the cup rack and pull-up the side.

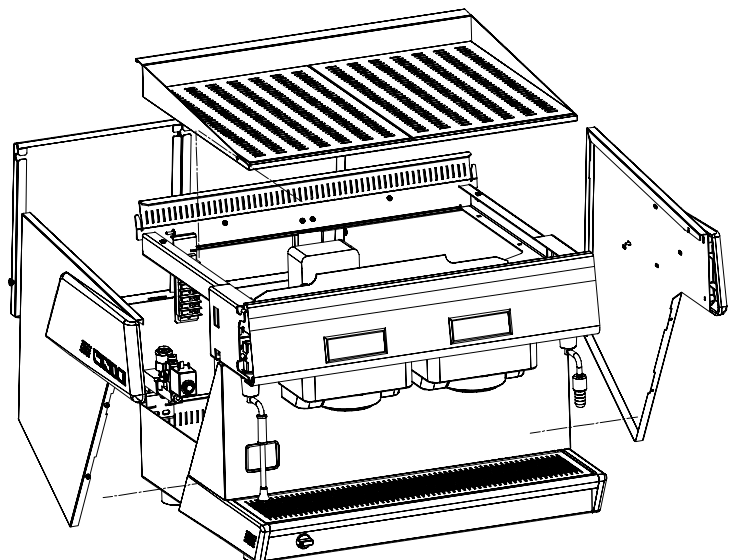

5.1 TEMPERATURE ADJUSTMENT BY MEANS OF THE ELECTRIC PRESSURE CONTROLLER

.The pressure controller (*pressurestat*) is located at the back..

.Dismantle the cup rack, remove the cover of the pressure controller to get to its adjustment screw.

- TIGHTEN to LOWER the temperature**
- LOOSEN to RAISE the temperature.**

.The pressure-gauge (red scale) must indicate a pressure of between 0.9 and 1 bar which corresponds to a temperature of 120°C.

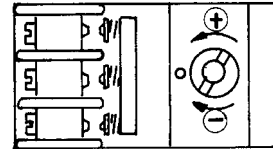
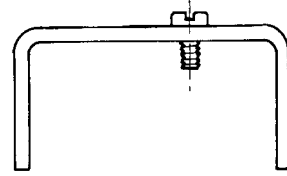

5.2 PRESSURE-RELEASE VALVE ADJUSTMENT

RUMBA Model

The HP valve is located on the right side of the machine: it is necessary to dismantle the sides and the rear panel.

The valve is set above the pump; its adjusted pressure must just be greater than the water network pressure. Recommended value: 7 to 8 bar (green scale of the pressure gauge).

- If the valve opens ABOVE 8 bar: LOOSEN
- If the valve opens BELOW 7 bar: TIGHTEN

Use a pin-wrench; after the adjustment, do not forget to block the counter nut.

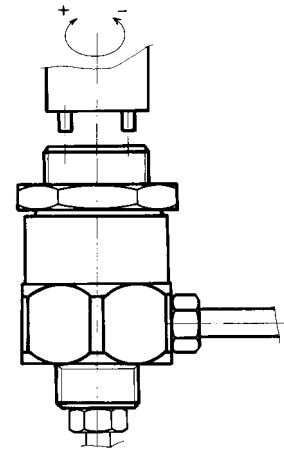

TWIN RUMBA and TRI RUMBA Models

The HP valve is located in the lower part at the left rear of the machine: it is necessary to dismantle the left side. The valve must open at about 13 bar (green scale of the pressure gauge).

- If the valve opens ABOVE 13 bar LOOSEN
- If the valve opens BELOW 13 bar TIGHTEN

Use a pin-wrench; after the adjustment, do not forget to block the counter nut.

5.3 PUMP - PRESSURE ADJUSTMENT

In infusion, the pressure must be between 9 and 10 bar (pressure gauge - green scale)

RUMBA Model

The pump is located in the left side and the adjustment must be done from the same side of the machine.

.TIGHTEN to INCREASE the pressure.
.LOOSEN to DECREASE the pressure.

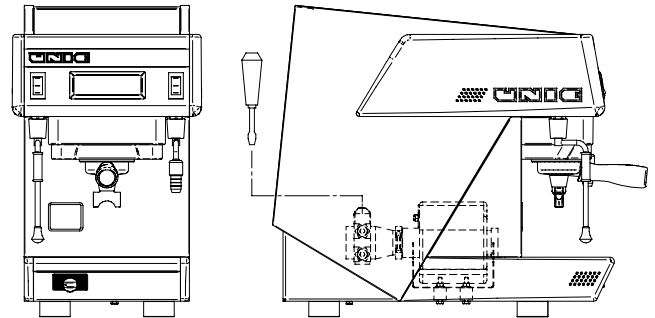

TWIN RUMBA and TRI RUMBA Model

The pump is located in the right side and the adjustment must be done from the same side of the machine.

.TIGHTEN to INCREASE the pressure.
.LOOSEN to DECREASE the pressure.

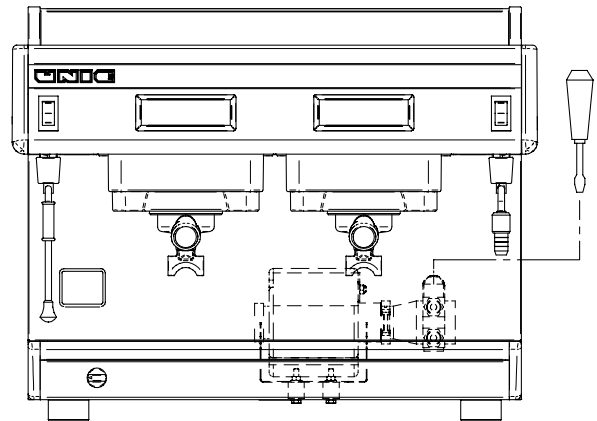

5.4 COFFEE GRINDING ADJUSTMENT

.Wait until the machine has reached the proper temperature (0.9 to 1 bar).

.The fineness of the grinding determines the time it takes for hot water to pass through the coffee.

.The passage-time is usually checked by using the 2-cup filter, with 2 doses of ground coffee.

.The average passage-time for 2 cups (6 to 7 cl. per cup) is from 30 to 35 seconds.

.If the passage-time is shorter, grind the coffee **finer**.

.If the passage-time is longer, grind the coffee **coarser**.

.For a good cup of coffee, use at least 6 gr. of ground coffee per cup.

FLUSHING INSTRUCTIONS

The unit is to be flushed prior to putting it into service, or after 24 hours of inactivity.

Dispense to the drain : - through each coffee head and water nozzle 0,5 litre of water
- through each steam nozzle some steam for 1 minute

"BEFORE PREPARING ANY BEVERAGE"

6. PROGRAMING OF THE DIFFERENT COFFEE QUANTITIES IN THE CUP

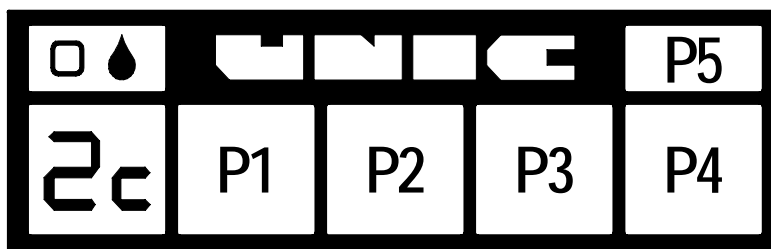

The keys from P1 à P4 can be programmed.

The multiple doses (1 , 2 ou 3 cups) are calculated automatically from the programming of one of them on each box.

1	Set the machine switch to Position 0.
2	Keep the key P5 pressed and put again the machine on. Display of Pn then Pc and Pr by pressing several times the key P5
3	Pc = CALCULATED PROGRAMMING Insert a filter-holder (with coffee) into the unit Install cups
	☞ P5 Display Pc
	☞ P1 à P4 Select the dose to be programed (2c for example)
	☞ P5 Start the infusion cycle
	☞ P5 Press again to stop when the amount of coffee desired is correct. Display of the corresponding digital value (from 00 à 99)
	Repeat operation at 3 for the other doses (2C for example)
4	Pn = DIGITAL PROGRAMMING Quick programming without coffee and/or values carried foward on other units.
	☞ P5 Display Pn
	☞ P1 à P4 Select the dose to be programed
	☞ P5 Dispaly of the digital value of the selected dose
	☞ P1 Increase the value
	☞ P4 Reduce the value
	€ P5 Memorize the new value
	Repeat operation at 4 for the other doses
5	Pr = MANUAL PROGRAMMING Same proceeding as in calculated programming Pc. The manual programming doesn't calculate the other doses (1, 2 or 3 cups), only the programed dose is modified. Caution: any new programming (Pn or Pc) cancel ALL previous programed values.
6	Wait until the program mode is automatically inactivated (from 10 to 15s), or switch off and on again the machine.

6.1 2 CUPS ELECTRONIC BOXES (type d2)

Continu / Stop key

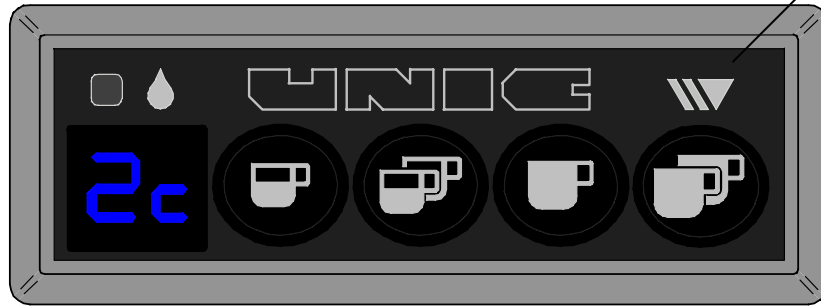

6.1a USE OF THE DOSES TO BE PROGRAMED

- 4 coffee doses and 1 manual function, Continu/Stop are available. During the infusion, it is displayed :
 - * 1c or 2c = 1 or 2 small cups
 - * 1C or 2C = 1 or 2 large cups
 - * C- = Continu/Stop
- At any time you can change the selection by pressing another key.
- The dosage is automatic but the infusion can be stopped manually by pressing the key Continu/Stop.
- Programing: The multiple doses being computed, only two programing are necessary (1c or 2c) and (1C or 2C).

6.1b CONFIGURATION PARAMETERS

- * dn / dt For the automatic calculation of the multiple doses
dn = normal dosage
dt = dosage with "Torino" kit
- * C0 / C1 Chronometer for the infusion time
C0 = no chronometer
C1 = display of the infusion time
- * A0 / A1 Authorization to program
A0 = prohibited programing
A1 = authorized programing

After switching on, the display shows the following information in order:

- The version number of the electronic memory: ex. r1
- The type of box: d2
- The active functioning parameters: ex. dn, CO, A1

6.1c MODIFICATIONS OF THE CONFIGURATION PARAMETERS

- Switch the machine off (switcher 0/1)
- Press simultaneously both keys P1 and P4, and in the same time, switch again the machine on
- Press the key P4 to change the selection (ex. dn or dt)
- Press the key P5 to change function (ex. dosage dn/dt or Chrono: C0/C1)
- Switch off to leave the configuration mode or wait the automatic leaving at the end of 10s.

6.2 3 CUPS ELECTRONIC BOXES (type d3)



6.2a USE OF THE DOSES TO BE PROGRAMED

- 6 coffee doses and 1 manual function, Continu/Stop are available. During the infusion, it is displayed :
 - * 1c, 2c ou 3c = 1, 2 or 3 small cups
 - * 1C, 2C or 3C= 1, 2 or 3 large cups
 - * C- = Continu/Stop
- At any time you can change the selection by pressing another key.
- The dosage is automatic but the infusion can be stopped manually by pressing the key Continu/Stop.
- Programming: The multiple doses being computed, only two programings are necessary (1c, 2c or 3c) and (1C, 2C or 3C). If it is necessary, the "Continu" dose can also be programmed.

6.2b CONFIGURATION PARAMETERS

- * dn / dt For the automatic calculation of the multiple doses
dn = normal dosage
dt = dosage with "Torino" kit
- * C0 / C1 Chronometer for the infusion time
C0 = no chronometer
C1 = display of the infusion time
- * A0 / A1 Authorization to program
A0 = prohibited programing
A1 = authorized programing
- * cc/cC/CC Start of infusion in small or large cup
cc = always starts in small cups
CC = always starts in large cups
cC = keep the last selection : c or C

After switching on, the display shows the following information in order:

- The version number of the electronic memory: ex. r1
- The type of box: d3
- The active functioning parameters: ex. dn, CO, A1, CC

6.2c MODIFICATIONS OF THE CONFIGURATION PARAMETERS

- Switch the machine off (switcher 0/1)
- Press simultaneously both keys P1 and P4, and in the same time, switch again the machine on
- Press the key P4 to change the selection (ex. dn or dt)
- Press the key P5 to change function (ex. dosage dn/dt or Chrono: C0/C1)
- Switch off to leave the configuration mode or wait the automatic leaving at the end of 10s.

7. DAILY CLEANING AND MAINTENANCE

Coffee unit :

- Carry out 2 or 3 infusion cycles without any coffee in the filter to clean the unit and the filter-holder joint (filter-holders not tightened)
- Wash the filter-holders and the filters in soapy water.

Overflow tray :

- Remove the overflow tray to empty it and rinse it under the tap.

Steam outlet tube :

- After each use, clean the steam tube with a wet rag and push steam push-button for a short moment to eliminate the small amount of liquid (milk) left inside the tube.

Body :

- Clean the body of the machine using a soft cloth and alcohol for the stainless-steel parts and a non-abrasive detergent for the painted parts.

Do not forget to regenerate your water softener periodically.

ATTENTION :

Air must be able to circulate freely all around the machine. The ventilation holes located at the rear and on the top of the machine must not be obstructed.

The machine is not to be operated without its legs.

Water Softener Regeneration : how ?

- A - Water intake
- B - Water outlet
- C - Intake tap
- D - Outlet tap
- E - Discharge pipe
- F - Regenerating pipe
- G - Lid wheel

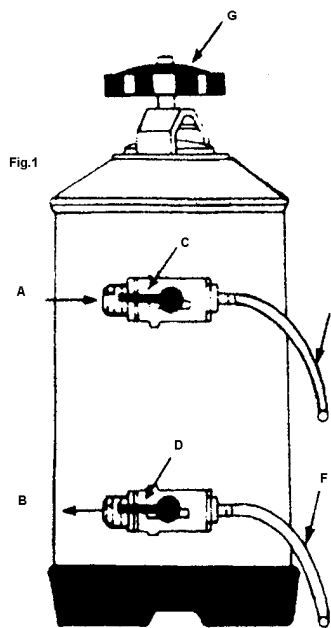

Use 1 kg of salt when the softener is 400 mm high.

Use 2 kg of salt when the softener is 600 mm high.

INSTRUCTIONS FOR USE :

- ① Install an empty vessel with a 2-litre capacity under Pipe E.

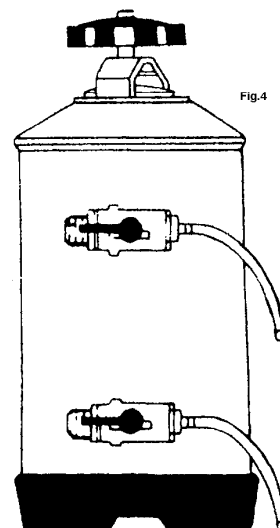
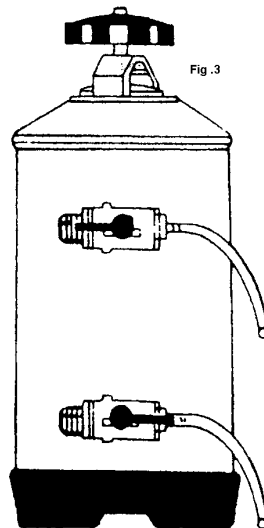
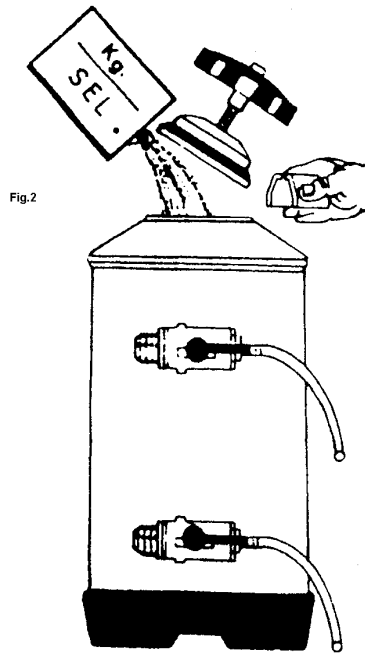

- ② Turn Handles C and D from the left to the right.

Unscrew G to remove the lid.

Insert salt.

- ③ Restore the lid to its initial position. Turn Handle C from the right to the left

Let the salted water run through Pipe F until it gets soft.

- ④ Turn Handle D from the right to the left

Water Softener Regeneration : when ?

Example :

Daily amount of used coffee : 3 kg

Number of 7-centilitre cups : 420

Daily water consumption : 30 litres

Daily number of 20-centilitre cups of tea : 150

Daily water consumption : 30 litres.

Conclusion : - Total daily water consumption is 60 litres

- Water hardness is 30°TH.

See 30°Column and line 60 of Table hereunder.

- DV 50 Water softener must be regenerated every 2 weeks.

- CN 97 Water softener must be regenerated every 5 weeks.

CN 97 Model Height : 600 mm Diam. : 185 mm Resin : 16 litres Salt : 2 kg										
Water hardness °TH		20°	25°	30°	40°	50°	60°	80°	Daily consumption	
Softened water → CN 97 Model		2500	2350	2100	1800	1600	1400	1000	Water in litres	Coffee in kg
		36	34	30	26	22	20	14	10	1
1	10	17	16	14	13	11	10	7	20	2
1,5	15	11	10	9	9	7	7	5	30	3
2	20	9	8	7	6	5	5	4	40	4
2,5	25	7	6	6	5	4	4	3	50	5
3	30	6	5	5	4	4	3	2	60	6
3,5	35	5	4	4	4	3	3	2	70	7
4	40	4	4	4	3	3	2	2	80	8
4,5	45	4	3	3	3	2	2	2	90	9
5	50	3	3	3	3	2	2	1	← NUMBER OF WEEKS BETWEEN 2 REGENERATING TREATMENTS ACCORDING TO FLOW CAPAC. & WATER °TH.	
6	60	3	3	2	2	2	2	1		
6,5	65	3	2	2	2	2	1	1		
7	70	2	2	2	2	1	1	1		
7,5	75	2	2	2	2	1	1	1		
8	80	2	2	2	2	1	1	1		
Coffee in kg Daily consumption	Water in litres	1200	1100	1000	900	760	700	500	Softened water DV 50 Model	
		20°	25°	30°	40°	50°	60°	80°	Water hardness °TH	
DV 50 Model Height : 400 mm Diam. : 185 mm Resin : 8 litres Salt : 1 kg										

8. CONNECTION TO A COMPUTER SYSTEM

A. GENERALITIES

Connection to a computer system (Hartwall, Walla, Remenco, ...)

The coffee machine informs the computer (in real time) about the number of cups of coffee and tea (made with temporized hot water). The computer is in charge of the management of the collected coffee machine data.

Each barman has got a coded badge that gives him permission to use the coffee machine and directly charge the served drinks.

B. MACHINE PREPARATION

Prior to being connected to a computer system, a coffee machine of the RUMBA range must be modified as follows:

1. Ref. 45026 and 45027 (with memory dated 22/07/97)

The following equipment is also supplied:

- 2. An interface box that records impulses coming from units and hot water outlets and transmit them to the computer**
- 3. The cables connecting the interface to the coffee machine**
- 4. A key switch to enter in programing mode.**

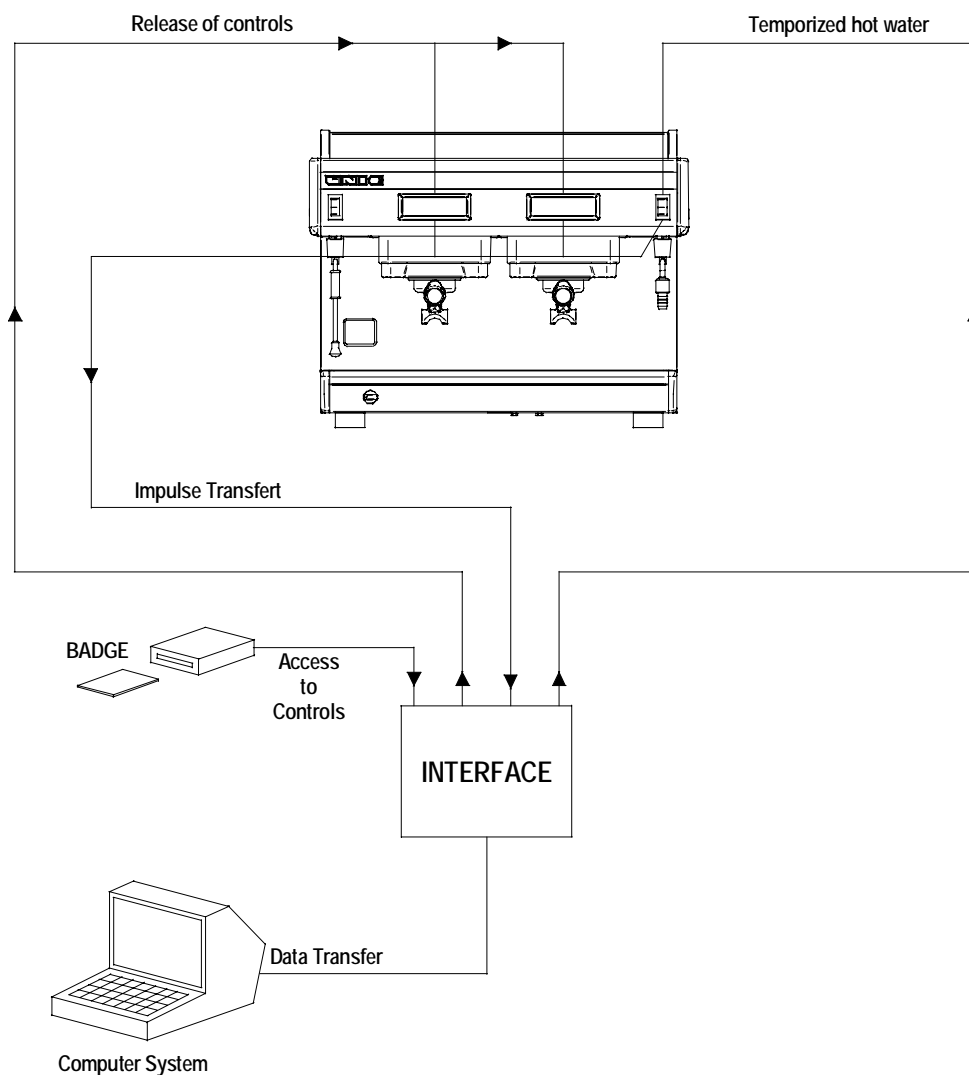

TROUBLE SHOOTING

VERY IMPORTANT

BEFORE TAKING ANY ACTION MAKE SURE THAT ALL THE ADJUSTMENTS ARE CORRECT.

1. TEMPERATURE 120°C

STEAM PRESSURE 0,9 to 1 bar (14 PSI)

2. INFUSION PRESSURE 9 to 10 bar (140 PSI)

High pressure valve opening : over 13 bar (188 PSI)

3. WATER SUPPLY PRESSURE 0 bar to 6 bar (0 PSI to 90 PSI)

If the machine "sucks" water directly from an external reservoir, check the water level in the reservoir and the non-return valve and filter fixed at the end of the inlet pipe.

4. PRECAUTIONS TO BE TAKEN

- ① Switch off the machine before any action on the electric circuits.
- ② Cool the machine and make the pressures down before any action on the hydraulic circuit.

9. DISPLAYED FAILURES

	Push button 1	See on § 9.1
	Push button 2	
	Push button 3	
	Push button 4	
	Push button 5	
	Fuse	See on § 9.2
	Time	See on § 9.3a → > 105 sec
	Metering + Time	See on § 9.3b → > 105 sec
	Dosage Metering	See on § 9.3b
	Short circuit Metering	See on § 9.3c
	Opened Metering	

9.1 PROBLEMS IN CONNECTION WITH THE ELECTRONIC BOXES'S CONTROL BUTTONS

If it is displayed P1, P2 ... or P5, this means that the corresponding key is in short-circuit and can't be used any more.

Remedy:

- Check that the front is not deformed
- Change the electronic box

9.2 FUSE PROBLEMS

Display: **F_**

F- is displayed when the fuse located at the back of the electronic box is "cut out".
The fuse can be reached from the upper part of the machine after removing the cup warmer.



If the fuse is "all right"

If the fuse is "cut out"



Check the fuse-holder

Clean fuse / fuse-holder contact points

**Check the box connections:
Do not invert wires
(valve and motor-pump wires)**

The cause must be determined, prior to fuse replacement.

Possible causes:

- The valve coil of the unit is short-circuited
- The motor-pump coil or R.C circuit is short-circuited
- The motor-pump or valve outlets of the electronic box are short-circuited (inside the box)
- Cables are short-circuited
- Fuse failure.



- Replace faulty elements
- Replace the fuse

*

9.3 DOSAGE PROBLEMS



9.3a 105-second safety system of the coffee unit

Thanks to such a safety system, the maximum infusion time is reduced and ranges from 1 minute to 45 seconds. As a result, the infusion process automatically stops, if the dosing device no longer works or if the flow capacity is insufficient so that the motor-pump and the valve of the unit are better protected.

When the safety system is on, **t** is displayed.

**The flow of the water going through the coffee filter is insufficient.
The infusion time corresponding to the programed dose is more than 105 seconds.**



The pump is faulty

Check:

- **The pressure**
- **Power supply:**
 - * **cables**
 - * **condenser**
- **The mechanical state of the motor-pump:**
 - * **filter**
 - * **coupling**

One of the water passage holes is clogged.

Check the hydraulic circuit:

- **Nozzle of dosing device**
- **Unit nozzle**
- **Unit filter**
- **Unit valve**
- **Coffee filters**
- **The spout**

The coffee grind is too fine:

- **Use a coarser grind.**

9.3b Metering safety system

During the infusion process, **cd** is displayed. This means that the dosing device has been no longer transmitting impulses to the unit electronic box for 5 seconds.

If the metering interruption is only temporary, the infusion cycle will stop as soon as the number of metered impulses matches the number of programed impulses.

Obviously the obtained dose will be heavier.

If the metering interruption is permanent, the infusion will stop automatically 105 seconds after the cycle has started and **ct** is displayed.

Or stop manually by pressing the Continu/Stop key. Display of **cd**

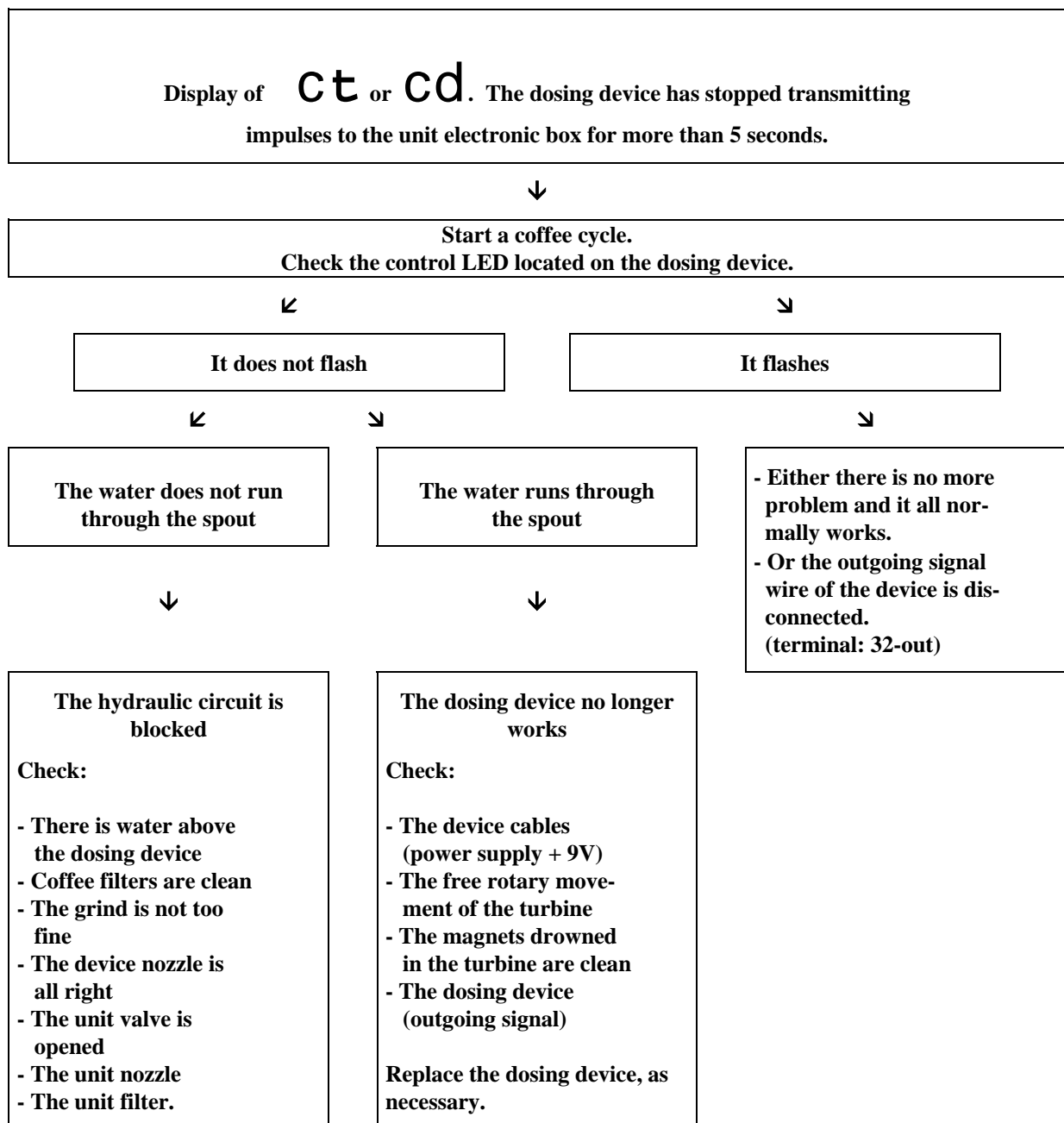

9.3c Dosing device safety system

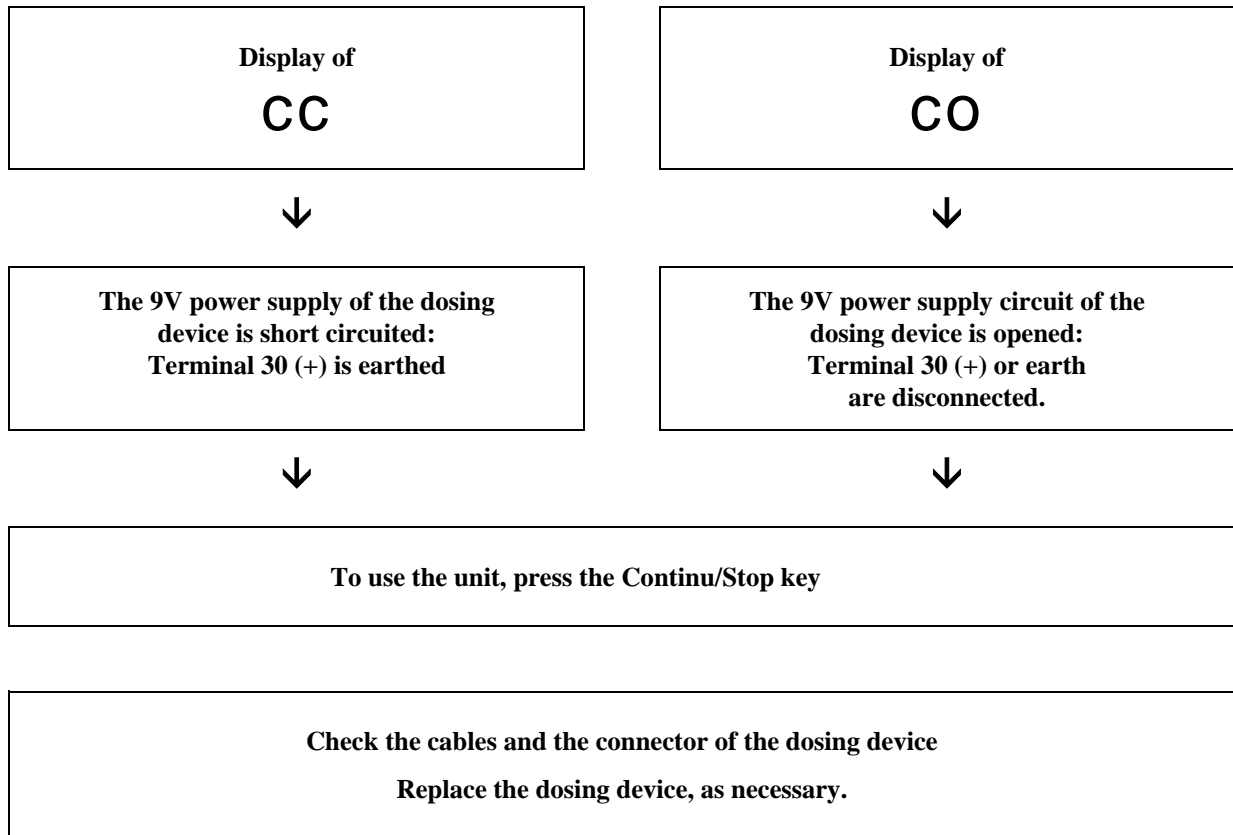

10. OTHER FAILURES

10.1 HYDRAULIC PROBLEMS OF THE COFFEE UNIT

10.1a Doses lighter than initially set

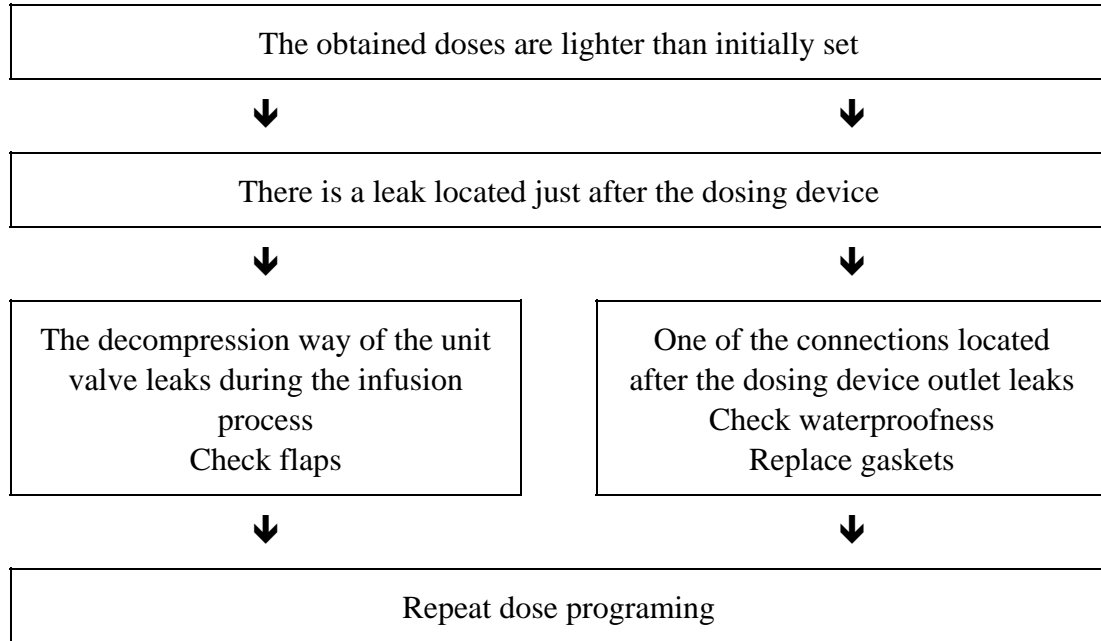

10.1b Dripping outside infusion periods

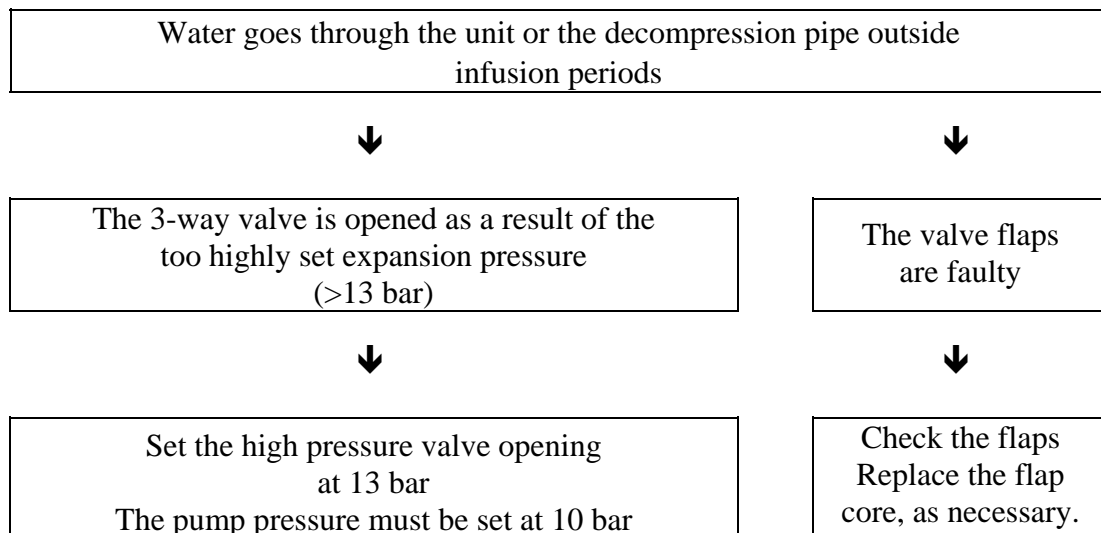

10.2 PROBLEMS IN CONNECTION WITH THE LEVEL REGULATION

10.2a The steam boiler is flooded

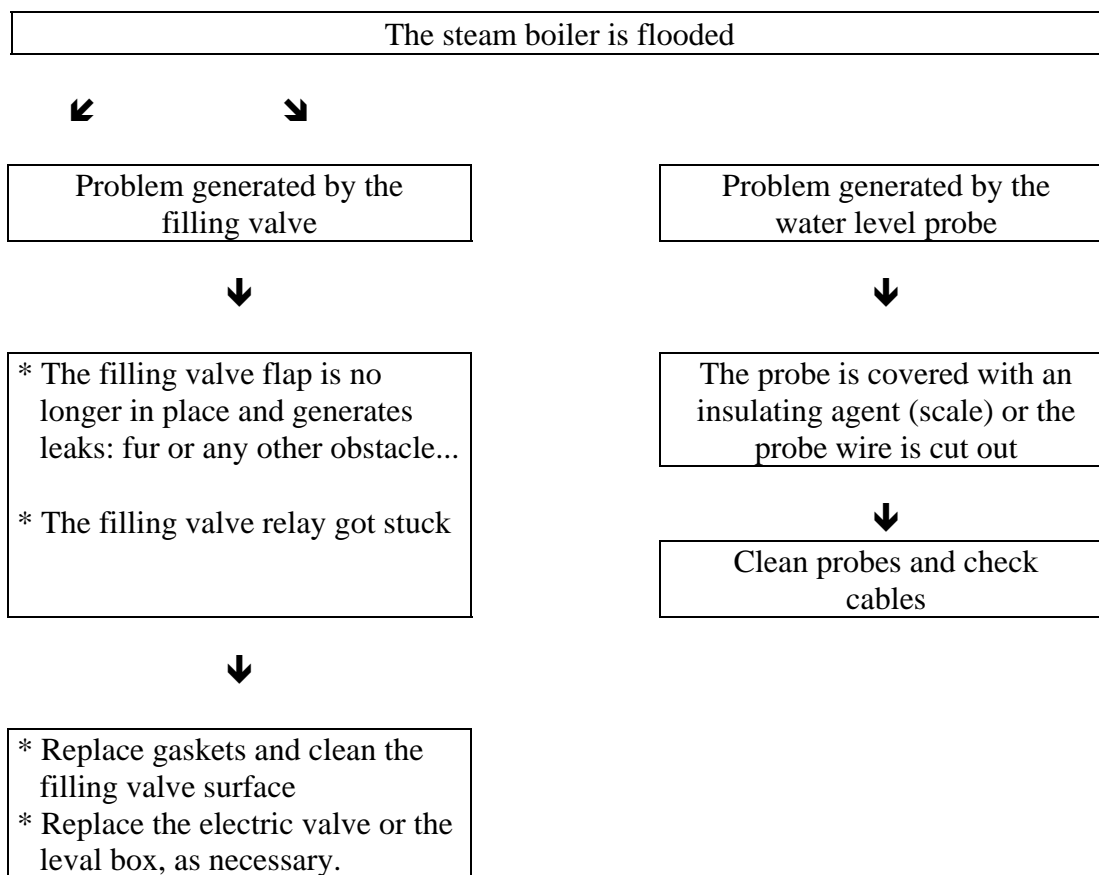

10.2b The boiler is empty

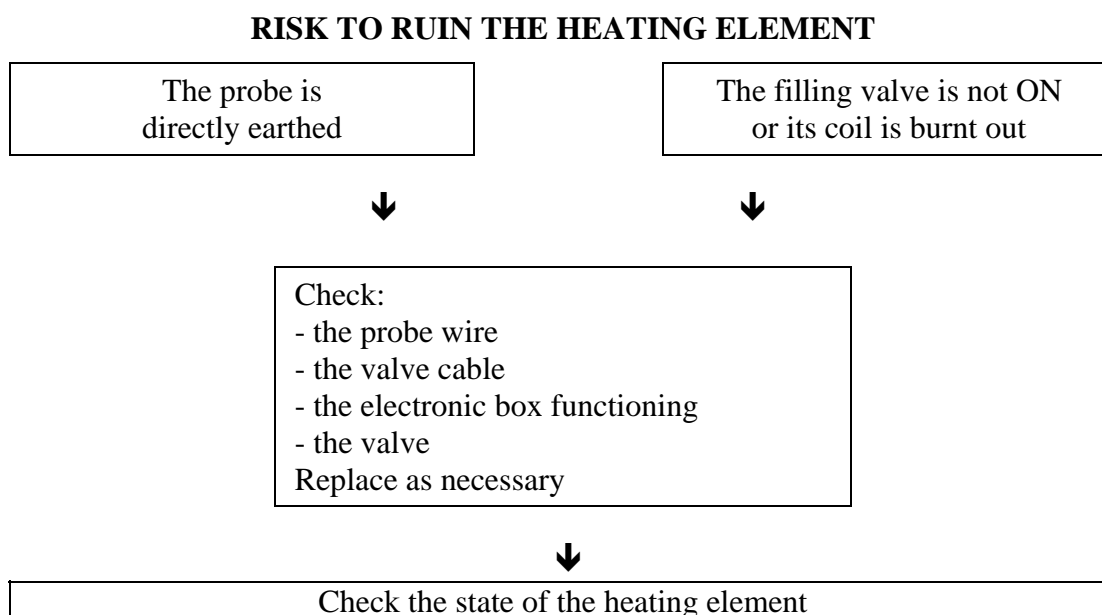







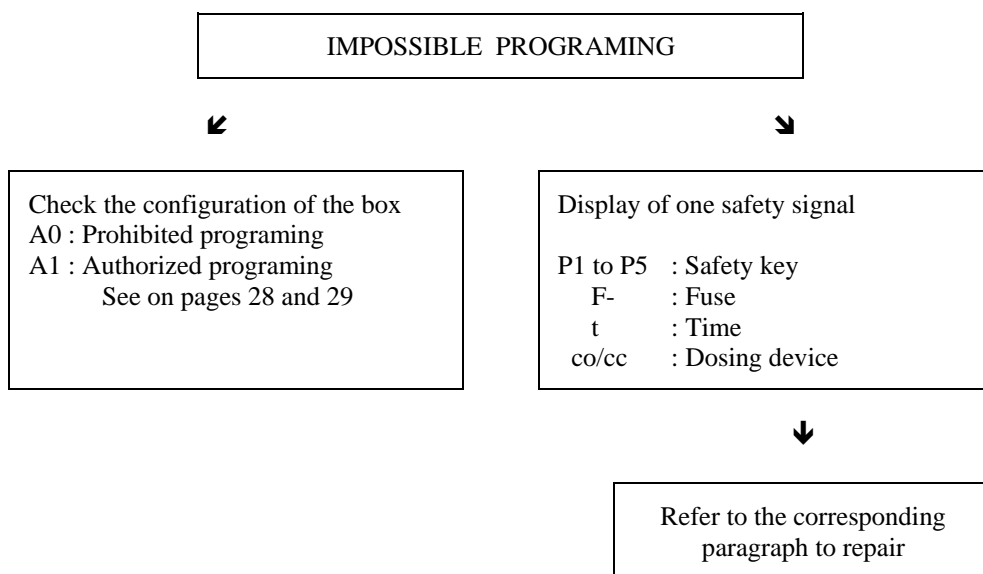

10.3 INSUFFICIENT OR NO HEATING PROCESS

- After getting a few cups of coffee, the machine gets "cold".
- Check the infusion time and adjust the grind accordingly.
- Make sure that each pin of the heating element works.

10.4 IMPOSSIBLE PROGRAMING

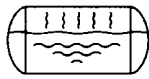

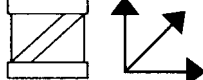
CARACTERISTIQUES TECHNIQUES / TECHNICAL CHARACTERISTICS

UNOQ	RUMBA	<i>twin</i> RUMBA	<i>tri</i> RUMBA
	Cm In.	31 12.2	65 25,6
	Cm In.	51 20	51 20
 NSF	Cm In.	59 23.2	59 23.2
	Cm In.	56 22	56 22
	L	6.3	10
	Kg lb	37 82	55 122
	Kg lb	40 88.6	75 166.5
	Cm In.	63X40X74 24.8X15.8X29.7	75X110X82 29,5X43,3X32.36
	KW	Mono seulement Mono only	
110 V mono 200 V mono 220 V mono - 380V tri + N 230 V mono - 400V tri + N 240 V mono - 415V tri + N	KW	1,7 2,3 2,7 3 3,2	- 2,3 / 3,5 2,7 / 4,3 3 / 4,7 3,2 / 5,1